

# LTA G2C100PC

## Pyroelektrischer Infrarot-Einelementsensord für Messtechnik-Applikationen

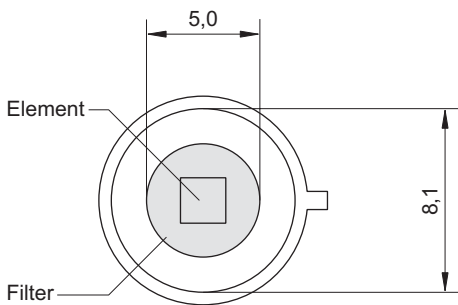
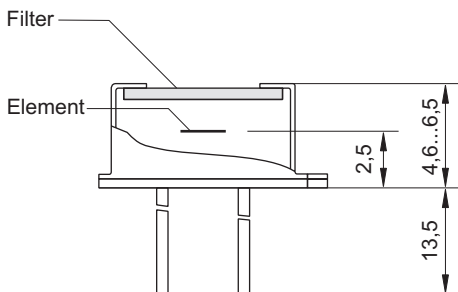
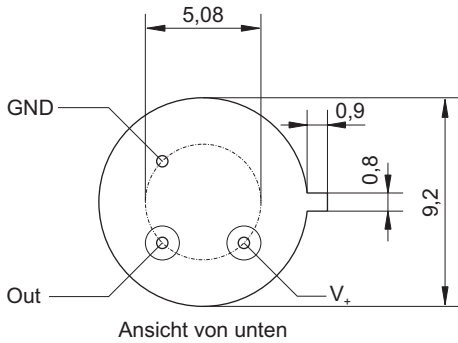

Elementgröße	2 mm × 2 mm
Apertur	5,0 mm
Filter <sup>3</sup>	kundenspezifisch
Empfindlichkeit <sup>1,2</sup>	>65000 V/W
Rauschspannung <sup>1</sup>	<20000 nV/√Hz
spezifische Detektivität <sup>1,2</sup>	>2,3·10 <sup>8</sup> cm √Hz / W
thermische Kompensation	parallel
Offsetspannung	<5 mV
Betriebsspannung	2,2 V bis 8 V
Gehäuse	TO 39
Betriebstemperatur	-20 bis 70 °C
Lagertemperatur	-20 bis 70 °C

- 1) Frequenz: 10 Hz, Umgebungstemperatur: 25 °C
- 2) Strahlertemperatur: 500 K, Filtertransmission: 100 %
- 3) andere Filter auf Anfrage

