

LTA G2I10PC

Pyroelektrischer Infrarot-Einelementsensord für Messtechnik-Applikationen

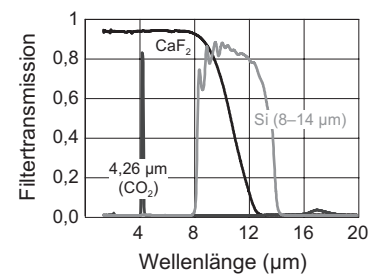
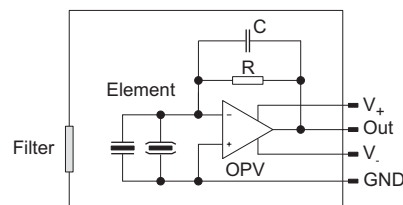
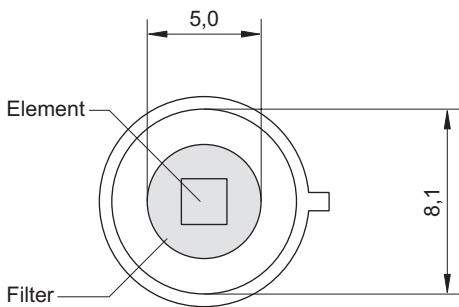
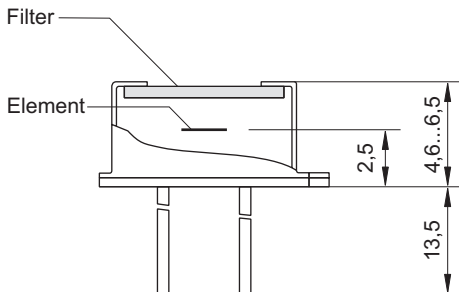
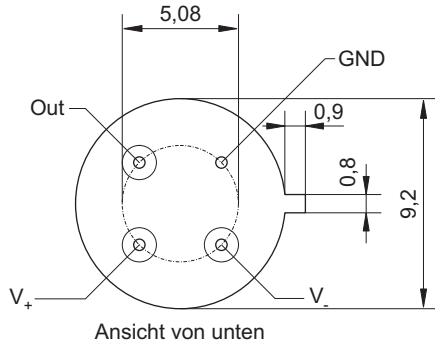

Elementgröße	2 mm × 2 mm
Apertur	5,0 mm
Filter ³	kundenspezifisch
Empfindlichkeit ^{1,2}	>14000 V/W
Rauschspannung ¹	<20000 nV/√Hz
spezifische Detektivität ^{1,2}	>1,4 · 10 ⁸ cm √Hz / W
thermische Kompensation	parallel
Offsetspannung	<5 mV
Betriebsspannung	±2,2 V bis ±8 V
Gehäuse	TO 39
Betriebstemperatur	-20 bis 70 °C
Lagertemperatur	-20 bis 70 °C

- 1) Frequenz: 10 Hz, Umgebungstemperatur: 25 °C
- 2) Strahlertemperatur: 500 K, Filtertransmission: 100 %
- 3) andere Filter auf Anfrage

