

LT G2

Pyroelektrischer Infrarot-Einelementsensor für Messtechnik-Applikationen

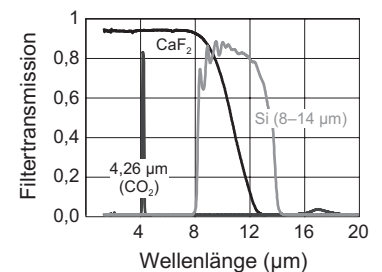
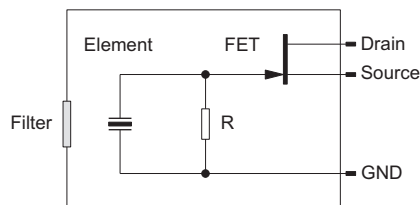
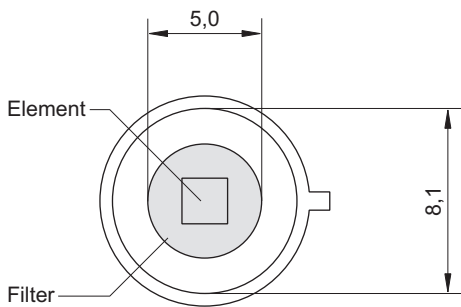
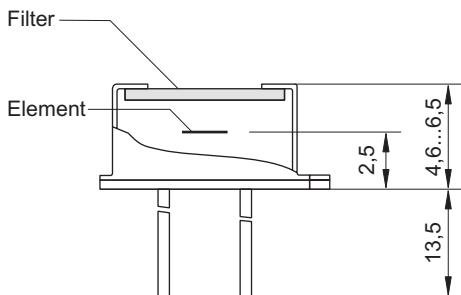
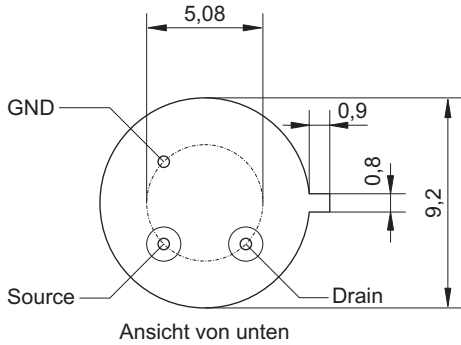

Elementgröße	2 mm × 2 mm
Apertur	5,0 mm
Filter ³	kundenspezifisch
Empfindlichkeit ^{1,2}	>300 V/W
Rauschspannung ¹	<170 nV/√Hz
spezifische Detektivität ^{1,2}	>3,5·10 ⁸ cm√Hz/W
Offsetspannung	0,4 bis 1,5 V
Betriebsspannung	2 V bis 18 V
Gehäuse	TO 39
Betriebstemperatur	-20 bis 70 °C
Lagertemperatur	-20 bis 70 °C

- 1) Frequenz: 10 Hz, Umgebungstemperatur: 25 °C
- 2) Strahlertemperatur: 500 K, Filtertransmission: 100 %
- 3) andere Filter auf Anfrage

