

# LTI Q2I10

## Pyroelektrischer Infrarot-Einelementsensor für Messtechnik-Applikationen

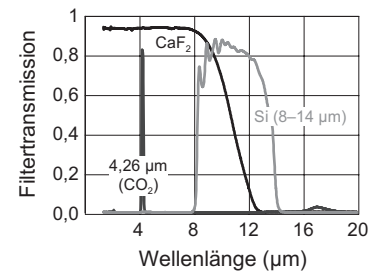
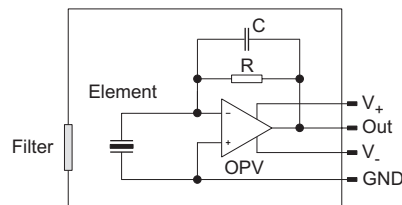
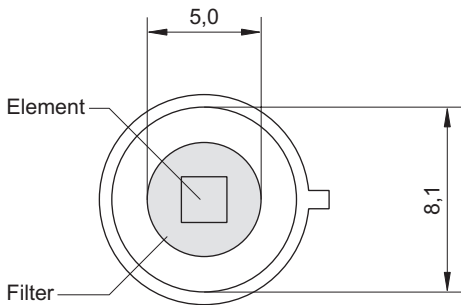
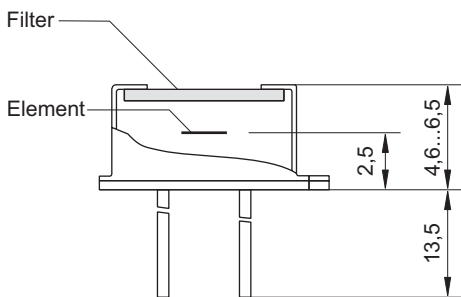
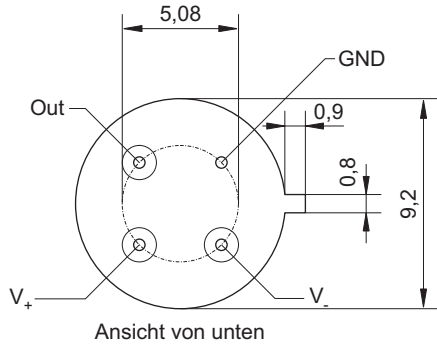

Elementgröße	2 mm × 2 mm
Apertur	5,0 mm
Filter <sup>3</sup>	kundenspezifisch
Empfindlichkeit <sup>1,2</sup>	>56000 V/W
Rauschspannung <sup>1</sup>	<22000 nV/√Hz
spezifische Detektivität <sup>1,2</sup>	>6,5 · 10 <sup>8</sup> cm √Hz / W
Offsetspannung	<5 mV
Betriebsspannung	±2,2 V bis ±8 V
Gehäuse	TO 39
Betriebstemperatur	-20 bis 70 °C
Lagertemperatur	-20 bis 70 °C

- 1) Frequenz: 10 Hz, Umgebungstemperatur: 25 °C
- 2) Strahlertemperatur: 500 K, Filtertransmission: 100 %
- 3) andere Filter auf Anfrage

