

LTSI Q1.2

Pyroelectric Single Element Detector for measurement application

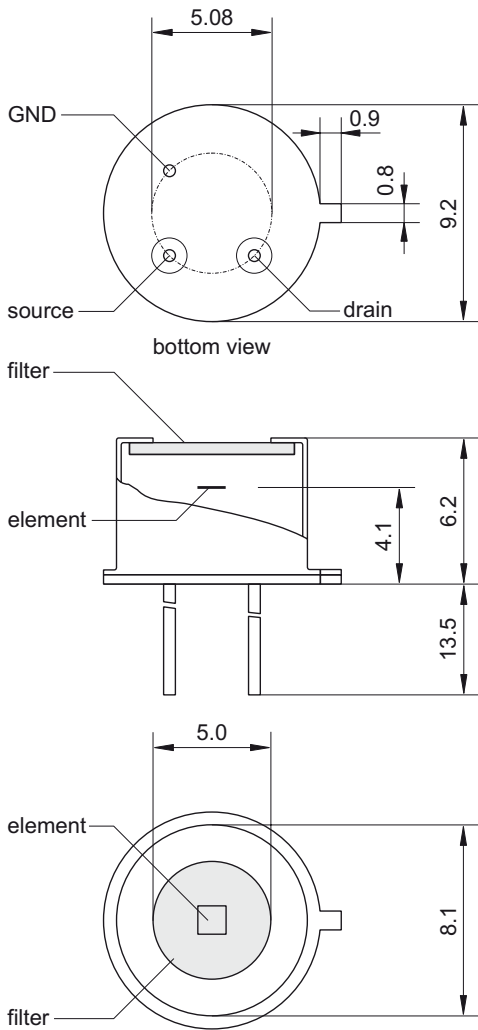

Element size	1.2 mm × 1.2 mm
Aperture	5.0 mm
Filter¹	custom-designed
Responsivity^{2,3}	> 900 V/W
Noise²	< 120 nV/√Hz
Specific detectivity^{2,3}	9·10 ⁸ cm√Hz/W
Offset voltage	0.4 to 1.5 V
Operating voltage	2 V to 18 V
Housing	TO 39
Operating temperature	-20 to 60 °C
Storage temperature	-20 to 60 °C

¹ Other filters on request. ² Frequency: 10 Hz, ambient temperature: 25 °C.
³ Black body source temperature: 500 K, Filter transmission: 100 %.

