

# LTSI Q2

## Pyroelektrischer Infrarot-Einelementsensor für Messtechnik-Applikationen

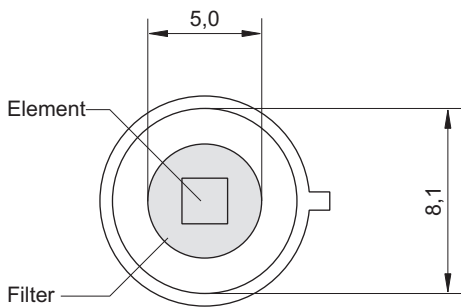
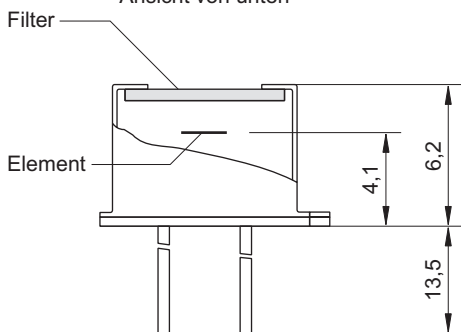
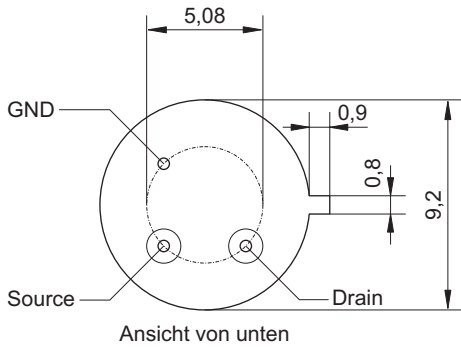

Elementgröße	2 mm × 2 mm
Apertur	5,0 mm
Filter <sup>3</sup>	kundenspezifisch
Empfindlichkeit <sup>1,2</sup>	>350 V/W
Rauschspannung <sup>1</sup>	<80 nV/√Hz
spezifische Detektivität <sup>1,2</sup>	>9·10 <sup>8</sup> cm √Hz/W
Offsetspannung	0,4 bis 1,5 V
Betriebsspannung	2 V bis 18 V
Gehäuse	TO 39
Betriebstemperatur	-20 bis 60 °C
Lagertemperatur	-20 bis 60 °C

- 1) Frequenz: 10 Hz, Umgebungstemperatur: 25 °C
- 2) Strahlertemperatur: 500 K, Filtertransmission: 100 %
- 3) andere Filter auf Anfrage

