

Kühlgehäuse Cooling jacket

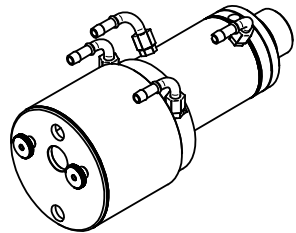
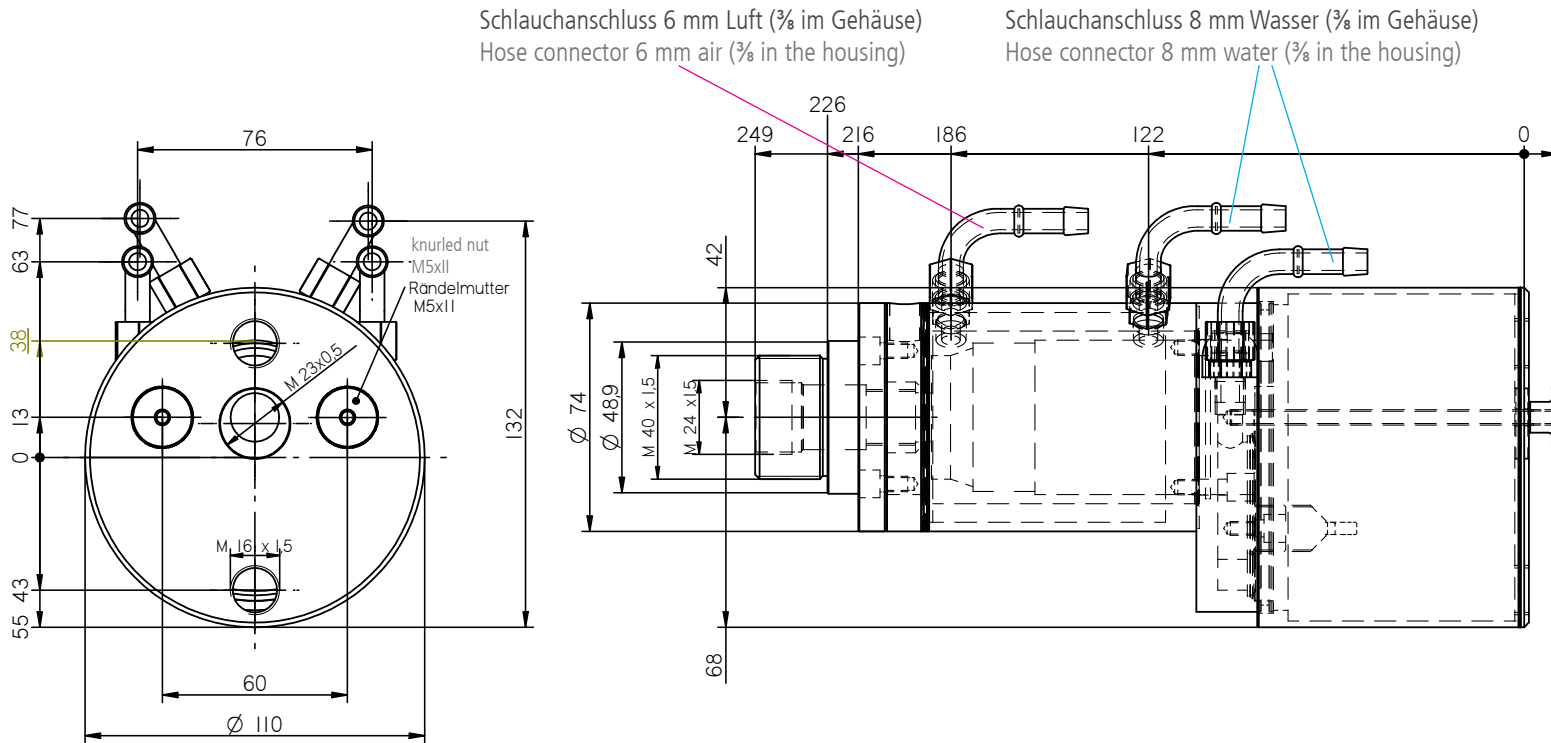

gratfrei burr Ra 0,8 /
 alle nicht bemaßten Fasen 0,5x45°
 all non-dimensioned chamfers 0,5x45°

Material: Edelstahl
 Blasluft öl-, staub- und wasserfrei
 Luftdruck: < 0,5 bar
 Luftdurchsatz: 1,5 m³/h
 Außentemperatur: max. 200 °C
 Wasserdruck: max. 10 bar
 Wassermenge (25 °C): 4 l/min
 Gesamtgewicht: ca. 3,3 kg

Material: Stainless steel
 Dry, clean air (free of oil and dust)
 Air pressure: < 0.5 bar
 Air volume: 1.5 m³/h
 Ambient temperature: max. 200 °C
 Water pressure: max. 10 bar
 Water consumption (25 °C): 4 l/min
 Total weight: approx .3.3 kg



| |
|--|
| Beschreibung: |
| Kühlgehäuse inkl. Luftpülung, ohne Montagewinkel |
| Bestellnummer: |
| 3310A23056 |
| Kompatible Geräte/Serien: |
| PYROSPOT Serie 56 |

| |
|---|
| Description: |
| Cooling jacket incl. air purge unit, without mounting angle |
| Order number: |
| 3310A23056 |
| Compatible devices/series: |
| PYROSPOT series 56 |