

# LTSI Q2PC

Pyroelectric Single Element Detector for measurement application

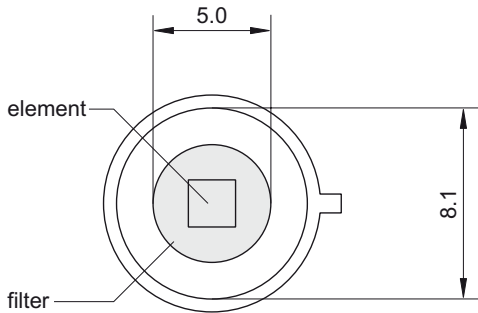
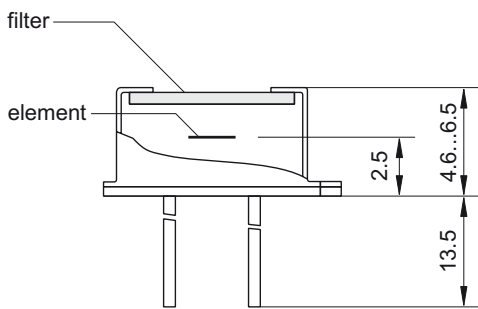
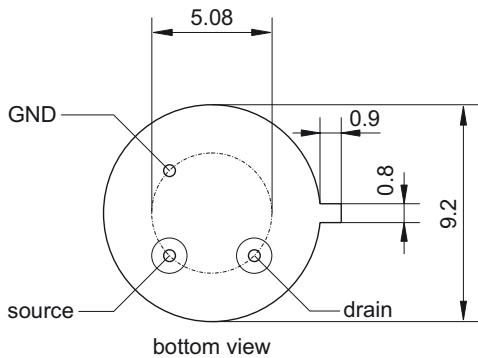

<b>Element size</b>	2 mm × 2 mm
<b>Aperture</b>	5.0 mm
<b>Filter<sup>1</sup></b>	custom-designed
<b>Responsivity<sup>2,3</sup></b>	> 170 V/W
<b>Noise<sup>2</sup></b>	< 55 nV/√Hz
<b>Specific detectivity<sup>2,3</sup></b>	7·10 <sup>8</sup> cm√Hz/W
<b>Thermal compensation</b>	parallel
<b>Offset voltage</b>	0.4 to 1.5 V
<b>Operating voltage</b>	2 V to 18 V
<b>Housing</b>	TO 39
<b>Operating temperature</b>	-20 to 60 °C
<b>Storage temperature</b>	-20 to 60 °C

<sup>1</sup> Other filters on request. <sup>2</sup> Frequency: 10 Hz, ambient temperature: 25 °C.

<sup>3</sup> Black body source temperature: 500 K, Filter transmission: 100 %.

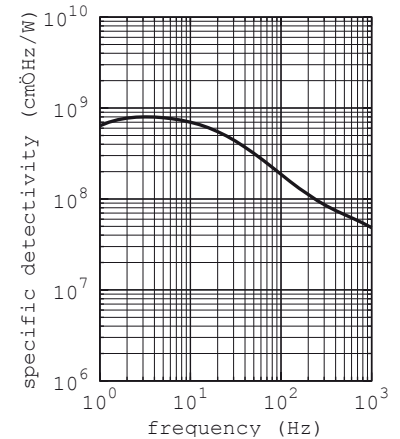
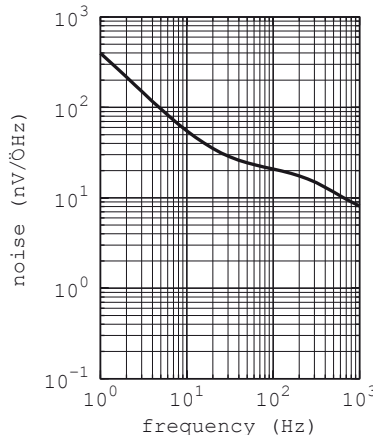
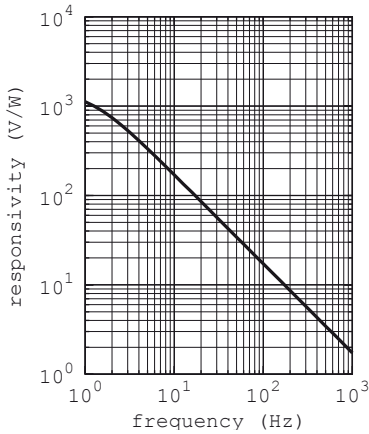
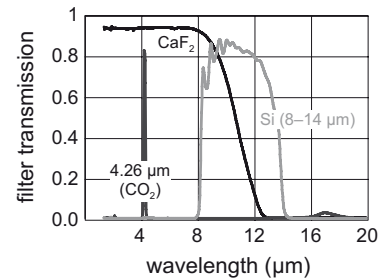
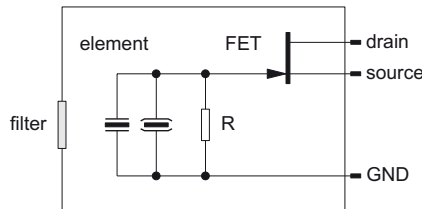

We are certified for many years according to ISO 9001

Phone: +49 351 896 74-0  
 Fax: +49 351 896 74-99  
 E-Mail: info@dias-infrared.de  
 Web: www.dias-infrared.com

DIAS Infrared GmbH  
 Pforzheimer Straße 21  
 01189 Dresden  
 Germany